

# NDR-240-48

240W Single Output Industrial DIN RAIL Power Supply



## Features

- Universal AC input / Full range
- Built-in active PFC function
- Protections: Short circuit / Overload / Over voltage / Over temperature
- Cooling by free air convection
- Can be installed on DIN rail TS-35/7.5 or 15
- UL 508 (industrial control equipment) approved
- EN61000-6-2 (EN50082-2) industrial immunity level
- 100% full load burn-in test
- 3 years warranty



**CB CE**

## Specification

MODEL		NDR-240-48
OUTPUT	DC VOLTAGE	48V
	RATED CURRENT	5A
	CURRENT RANGE	0 ~ 5A
	RATED POWER	240W
	RIPPLE & NOISE (max.) Note.2	150mVp-p
	VOLTAGE ADJ. RANGE	48 ~ 55V
	VOLTAGE TOLERANCE Note.3	±1.0%
	LINE REGULATION	±0.5%
	LOAD REGULATION	±1.0%
	SETUP, RISE TIME	1500ms, 100ms/230VAC 3000ms, 100ms/115VAC at full load
HOLD UP TIME (Typ.)	28ms/230VAC 22ms/115VAC at full load	
INPUT	VOLTAGE RANGE Note.4	90 ~ 264VAC 127 ~ 370VDC
	FREQUENCY RANGE	47 ~ 63Hz
	POWER FACTOR (Typ.)	PF>0.98/115VAC, PF>0.95/230VAC at full load
	EFFICIENCY (Typ.)	90%
	AC CURRENT (Typ.)	2.5A/115VAC 1.3A/230VAC
	INRUSH CURRENT (Typ.)	20A/115VAC 35A/230VAC
LEAKAGE CURRENT	<1mA / 240VAC	
PROTECTION	OVERLOAD	105 ~ 130% rated output power Protection type : Constant current limiting, recovers automatically after fault condition is removed
	OVER VOLTAGE	56 ~ 65V Protection type : Shut down o/p voltage, re-power on to recover
	OVER TEMPERATURE	Shut down o/p voltage, recovers automatically after temperature goes down
ENVIRONMENT	WORKING TEMP.	-20 ~ +70°C (Refer to "Derating Curve")
	WORKING HUMIDITY	20 ~ 95% RH non-condensing
	STORAGE TEMP., HUMIDITY	-40 ~ +85°C, 10 ~ 95% RH
	TEMP. COEFFICIENT	±0.03%/°C (0 ~ 50°C)
SAFETY & EMC (Note 4)	VIBRATION	Component: 10 ~ 500Hz, 2G 10min./1cycle, 60min. each along X, Y, Z axes; Mounting: Compliance to IEC60068-2-6
	SAFETY STANDARDS	UL508, TUV EN60950-1, EAC TP TC 004, BSMI CNS14336-1 approved ;(meet EN60204-1)
	WITHSTAND VOLTAGE	I/P-O/P:3KVAC I/P-FG:2KVAC O/P-FG:0.5KVAC
	ISOLATION RESISTANCE	I/P-O/P, I/P-FG, O/P-FG:>100M Ohms / 500VDC / 25°C / 70% RH
	EMC EMISSION	Compliance to EN55032 (CISPR32), EN61204-3 Class B, EN61000-3-2,-3, EAC TP TC 020, CNS13438
EMC IMMUNITY	Compliance to EN61000-4-2,3,4,5,6,8,11, EN55024, EN61000-6-2 (EN50082-2), EN61204-3, heavy industry level, criteria A, EAC TP TC 020	

<b>MODEL</b>	<b>NDR-240-48</b>	
<b>OTHERS</b>	<b>MTBF</b>	230.2K hrs min. MIL-HDBK-217F (25°C)
	<b>DIMENSION</b>	63*125.2*113.5mm (W*H*D)
	<b>PACKING</b>	1Kg; 12pcs/13Kg/1.1CUFT
<b>NOTE</b>	<ol style="list-style-type: none"> <li>All parameters NOT specially mentioned are measured at 230VAC input, rated load and 25°C of ambient temperature.</li> <li>Ripple &amp; noise are measured at 20MHz of bandwidth by using a 12" twisted pair-wire terminated with a 0.1uf &amp; 47uf parallel capacitor.</li> <li>Tolerance : includes set up tolerance, line regulation and load regulation.</li> <li>Derating may be needed under low input voltage. Please check the derating curve for more details.</li> <li>Installation clearances : 40mm on top, 20mm on the bottom, 5mm on the left and right side are recommended when loaded permanently with full power. In case the adjacent device is a heat source, 15mm clearance is recommended.</li> <li>The power supply is considered a component which will be installed into a final equipment. The final equipment must be re-confirmed that it still meets EMC directives. For guidance on how to perform these EMC tests, please refer to "EMI testing of component power supplies."</li> <li>The ambient temperature derating of 3.5°C/1000m with fanless models and of 5°C/1000m with fan models for operating altitude higher than 2000m (6500ft).</li> </ol>	

## Mechanical Specification

Case No.979C Unit:mm

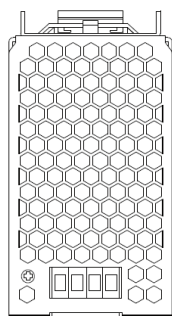

Top View

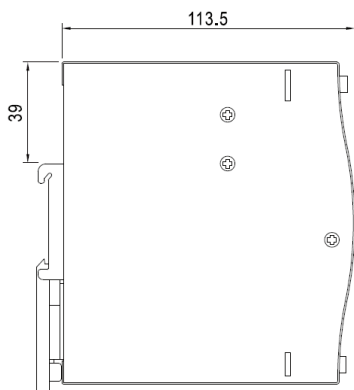

Side View

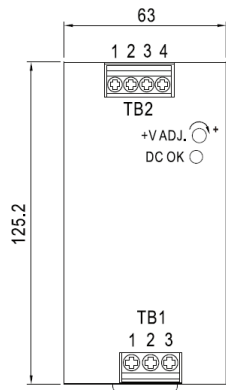

Front View

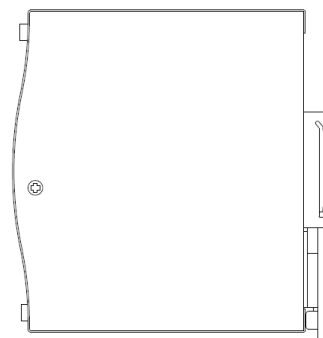

Side View

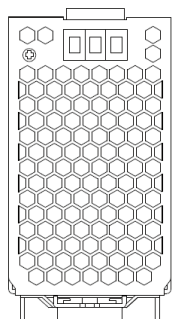

Bottom View

### Terminal Pin No. Assignment (TB1)

Pin No.	Assignment
1	FG ⚡
2	AC/N or DC -
3	AC/L or DC +

### Terminal Pin No. Assignment (TB2)

Pin No.	Assignment
1,2	DC OUTPUT -V
3,4	DC OUTPUT +V

## Installation Instruction

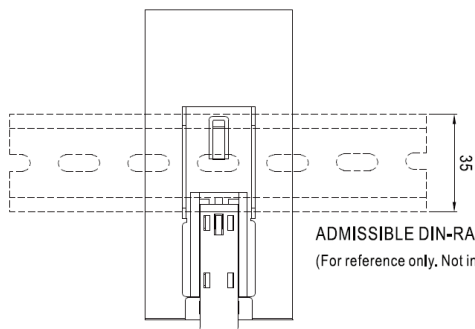

Back View

ADMISSIBLE DIN-RAIL: TS35/7.5 OR TS35/15  
(For reference only. Not included with unit.)

This series fits DIN rail TS35/7.5 or TS35/15.  
For installation details, please refer to the Instruction manual.

## Block Diagram

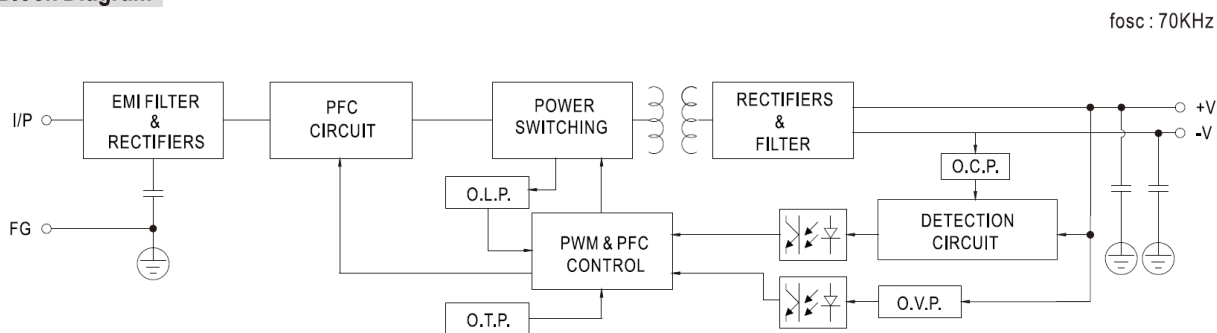

## Derating Curve

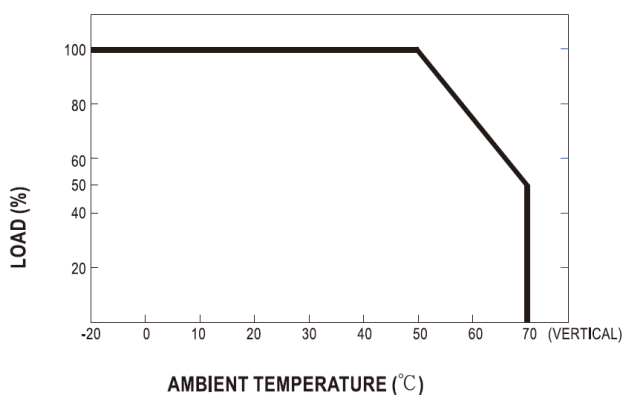

## Output derating VS input voltage

