



MCT-RACK-2 Series

2-Slot Media Converter Chassis

User's Guide

Version: 1.1

Revision History

Version	Date	Changes
1.0	08/10/2018	First release
1.1	12/04/2018	Add the DC version of chassis

FCC Warning

This equipment has been tested and found to comply with the limits for a Class A digital device, pursuant to Part 15 of the FCC Rules. These limits are designed to provide reasonable protection against harmful interference when the equipment is operated in a commercial environment. This equipment generates, uses, and can radiate radio frequency energy and, if not installed and used in accordance with this user's guide, may cause harmful interference to radio communications. Operation of this equipment in a residential area is likely to cause harmful interference in which case the user will be required to correct the interference at their own expense.

CE Mark Warning

This is a Class A product. In a domestic environment, this product may cause radio interference in which case the user may be required to take adequate measures.

Trademarks

CTS is a registered trademark of Connection Technology Systems Inc
All trademarks belong to their respective proprietors.

Contents subject to change without prior notice.

Copyright Statement

Connection Technology Systems Inc Copyright © 1998-2018

This publication may not be reproduced as a whole or in part, in any way whatsoever unless prior consent has been obtained from Connection Technology Systems Inc.

CTS Contact Information

■ **Headquarter/Manufacturer:**

Connection Technology Systems Inc.

18F-6, No.79, Sec.1, Xintai 5th Rd.,
XiZhi Dist., New Taipei City 221, Taiwan(R.O.C)
Tel: +886-2-2698-9661
Fax: +886-2-2698-9662
Dir.Line:+886-2-2698-9201
www.ctsystem.com

■ **Global Authorized Representatives:**

Connection Technology USA Inc.

40538 La Purissima Way, Fremont, CA 94539, USA
Tel: +1-510-509-0304
Sales Direct Line: +1-510-509-0305
E-mail:cts_us@ctsystem.com

Connection Technology Systems Japan

Higobashi Bldg, No3 R201, 1-23-13, Edobori, Nisi-ku,
Osaka 550-0002, Japan
Tel: +81-6-6450-8890
E-mail: cts_japan@ctsystem.com

Connection Technology Systems NE AB

August Barks Gata 21,
421 32 Västra Frölunda, Sweden
Tel: +46-31-221980
E-mail: info@ctsystem.se

COMPONET Handels GmbH

Hirschstettner Straße 19-21/Stiege I
A-1220 Wien, Austria
Tel: +43-1-2350-5660
E-mail: office@componet.at

Table of Contents

Revision History	ii
CTS CONTACT INFORMATION	III
TABLE OF CONTENTS	IV
CHAPTER 1. INTRODUCTION	2
1.1 OVERVIEW OF MCT-RACK-2.....	2
1.2 HARDWARE FEATURES	2
1.3 FRONT & REAR PANELS.....	4
1.3.1 Front Panel.....	4
1.3.2 Rear Panel	6
1.4 LED DEFINITIONS	7
CHAPTER 2. INSTALLATION	8
2.1 INSTALLATION REQUIREMENTS	9
2.2 CHECKING THE PACKAGE CONTENTS	9
2.3 INSTALLING MCT SERIES MEDIA CONVERTER MODULES	10
2.4 INSTALLING MCT-RACK-2 CHASSIS	12
2.4.1 Desktop Installation.....	12
2.4.2 Rack Installation	13
2.4.2.1 Install a Single MCT-RACK-2 Chassis in a 10-inch Rack	13
2.4.2.2 Install a Single MCT-RACK-2 Chassis in a 19-inch Rack	15
2.5 POWERING ON MCT-RACK-2 CHASSIS	16
CHAPTER 3. MAINTENANCE	17
3.1 FAULT IDENTIFICATION	17
3.1.1 Local Check	17
3.2 HARDWARE REPLACEMENT PROCEDURES	18
3.2.1 Replace MCT Series Media Converter	18

About this manual

In this user's guide, it will not only clearly introduce CTS MCT-RACK-2 Media Converter Chassis but tell you how to install our MCT series media converters into this chassis with detailed instructions.

Organization of the Manual

- Chapter 1 "Introduction" describes the features of the Media Converter Chassis
- Chapter 2 "Installing the Media Converter Chassis"
- Chapter 3 "Operation"
- Chapter 4 "Maintenance"

1

Introduction

CTS's Media Converter Chassis is designed to collect media converters together in order to meet the emerging FTTX & Metro Ethernet requirements. Its low profile appearance with 1U height and the standard rack-mounted size achieve the highest density within a single rack. When massive fiber ports need to be deployed, the Media Converter Chassis provides the best performance and price ratio.

1.1 Overview of MCT-RACK-2

MCT-RACK-2, the compact media converter and rack mountable chassis, provides 2 slots for the mixed installation of non-managed and managed MCT series media converters. Up to 2 media converters can be powered by the MCT-RACK-2 without any external power supply required. LED indicators located on the front panel ease the users' effort to monitor the power and fan status.

Moreover, with the height of 1U and the half-size rack design in appearance, MCT-RACK-2 can be used in closet wiring as well, which is especially suitable for the small cabinet and narrow space installation environment.

1.2 Hardware Features

- 8.5 inches (width) x 1U (height)
- Offer 2 converter slots
- Unique front access design for effortless installation and maintenance
- Support the rack-mount installation with the rack-mount kit
- With the built-in DC power supply unit
- Support Plug & Play for converter modules

Introduction

- Power Consumption: 2~16W (when powering 2 x 10G media converters)
- Operation Environment
 - Operating Temperature: 0°C~50°C
 - Storage Temperature: -20°C~60°C
- Weight: 1.13Kg (Exclude converter modules)

1.3 Front & Rear Panels

1.3.1 Front Panel

Either AC input or DC input type of power module is provided for MCT-RACK-2 chassis.

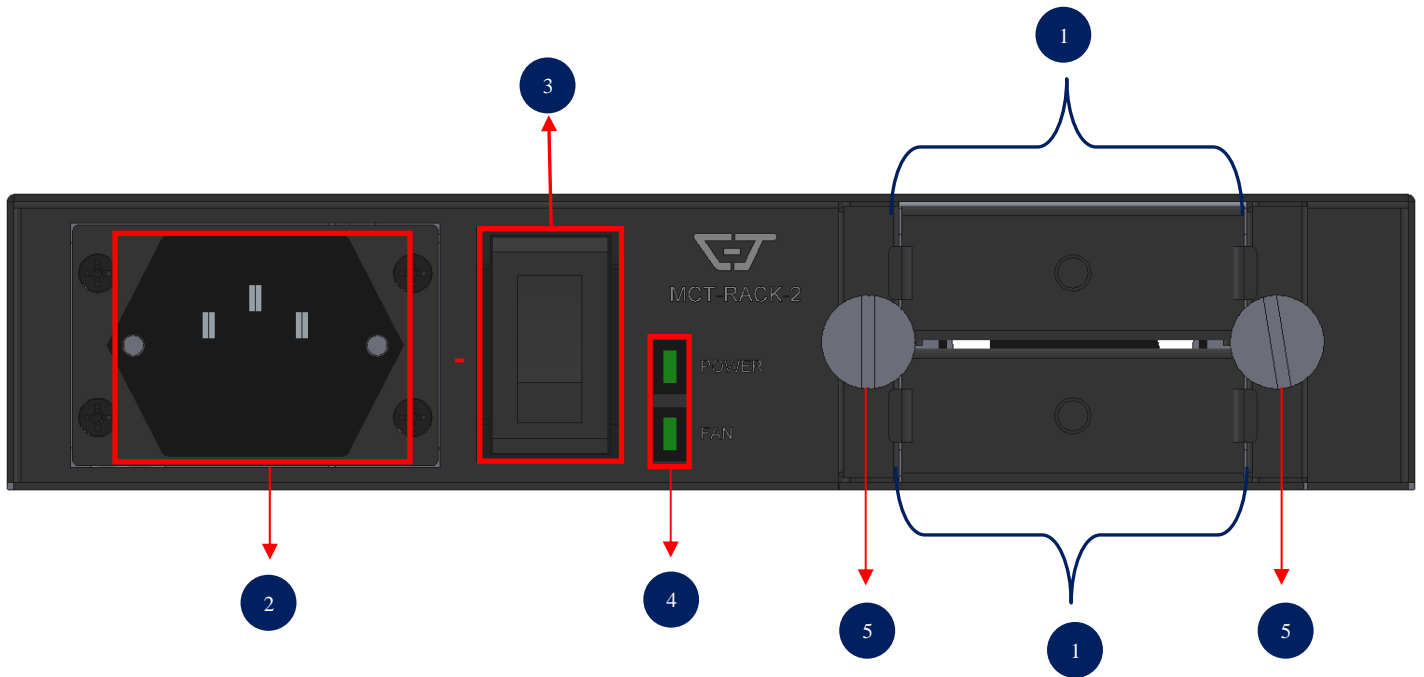

Figure 1-1. Front Panel of MCT-RACK-2 Chassis with AC Power Module



Figure 1-2. Front Panel of MCT-RACK-2 Chassis with DC Power Module

The interfaces on the front panel of MCT-RACK-2 are described below:

- 1. 2 x Slots for MCT Series Media Converters:**
- 2. Power Module and Connector:**
 - The type of power module is AC input.
 - AC power connection: 100-240V, 50/60Hz, 0.75A-0.5A.
- 3. Power Switch:**
 - Power on/off MCT-RACK-2 chassis.
- 4. LEDs:**
 - Includes LEDs of power and fan. For more details on LEDs description, please refer to Section [1.4 LED Definitions](#).
- 5. Fastening Knobs:**
 - Used for installing or removing the converter modules. For more details on these installation, please refer to Chapter 2.
- 6. Power Module and Connector:**
 - The type of power module is DC input.
 - DC power connection: 24V~48V, 0.4A~0.17A

1.3.2 Rear Panel

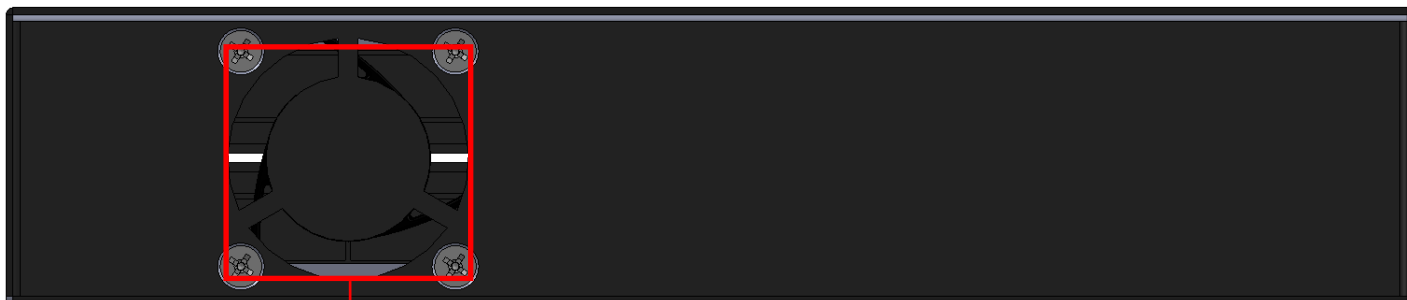

Figure 1-3. Rear Panel of MCT-RACK-2 Chassis

7

The interface on the rear panel of MCT-RACK-2 is described below:

7. **FAN (Fixed):**
 - Used for device's heat dissipation.

1.4 LED Definitions

MCT-RACK-2 is Plug & Play compliant. The power and fan status can be monitored through the LED indicators located on the front panel of this chassis. The real-time operational status also can be monitored through a set of LED indicators located on the front panel of the slide-in converter module.

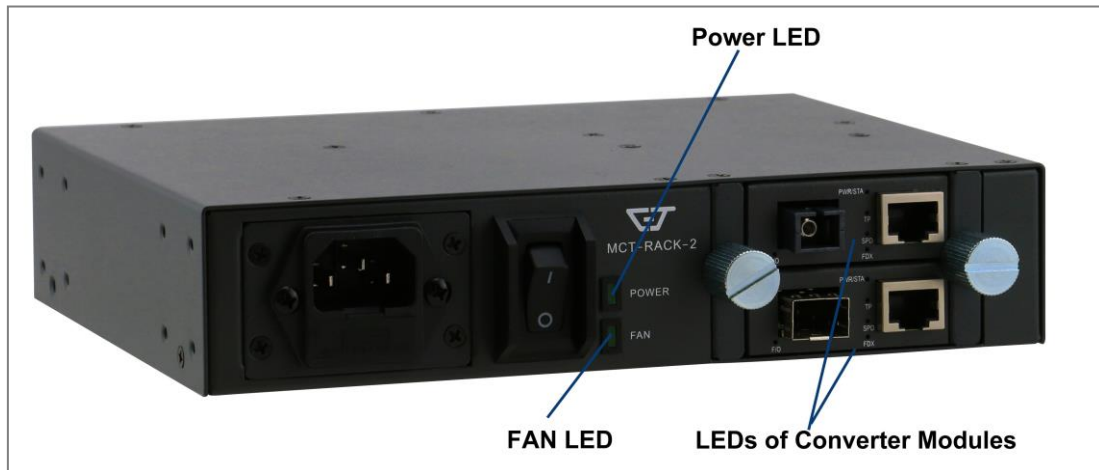

Figure 1-4. LEDs of MCT-RACK-2 Chassis and the Slide-in Converter Modules

Power LED of the Chassis

The power status of the chassis is indicated by the Power LED on the front panel of the device.

LED	Color	Operation
POWER	OFF	No fixed-in power module exists or power is off.
	Green	Lit when power module is in normal operation.

Fan LED of the Chassis

The fan status of the chassis is indicated by the FAN LED on the front panel of the device.

LED	Color	Operation
FAN	OFF	No fixed-in fan module exists or fan fails.
	Green	Lit when the fan module is activated.

LEDs of Converter Modules in Slot 1 and Slot 2

Different converter modules may have different LED indicators. For more details on its LEDs description, please refer to the user's manual of MCT series media converters you bought.

2

Installation

To properly install MCT-RACK-2 chassis, please follow the procedures listed below. These procedures will be respectively described in detail in the following sections.

- Installation Requirements
- Checking the Package Contents
- Installing MCT Series Media Converter Modules
- Installing MCT-RACK-2 Chassis
- Powering on MCT-RACK-2 Chassis

2.1 Installation Requirements

Basic requirements for installation are as follows:

- Environmental conditions
 - One power outlet
 - Proper ventilation
 - Proper isolation to electrical noise, radio, etc.
 - UTP cables for converter modules should not run in the same duct with power and phone line cables
- Required SFP Transceiver or UTP cables for converter modules
- Rack mounting tools

2.2 Checking the Package Contents

Unpack the package carefully and check the package contents. The package should contain the following items:

- One set of MCT-RACK-2 Chassis
- 19-inch rack-mount kit:
 - 1x long mounting bracket and 2x regular mounting brackets
 - Screws
- Four rubber feet with adhesive backing
- Documentation CD
- AC power cord (For AC power module only)
- 1x pulling cable

If any item is found missing or damaged, please contact your local sales representative for support or replacement.

2.3 Installing MCT Series Media Converter Modules

To install your media converter modules into MCT-RACK-2 chassis, just follow the procedures listed below for step-by-step instructions.



CAUTION

To prevent any damage or failure of MCT series media converters, please wear a grounding device and observe electrostatic discharge precautions before installing into MCT-RACK-2.

- ❶ Plan the MCT Series Media Converters slot positions.
- ❷ Loosen the fastening knobs counterclockwise. (See Fig. 2-1.)
- ❸ Remove the cover plate from the selected installation slot. (See Fig. 2-2.)

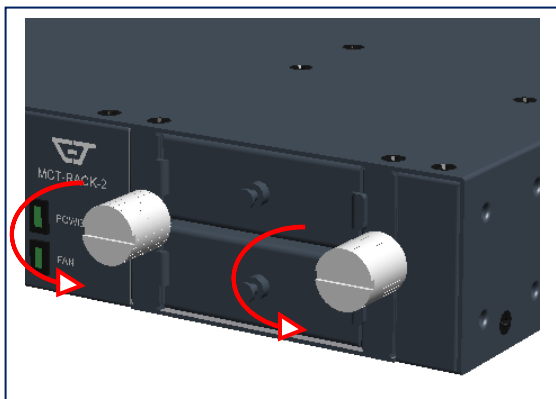

Figure 2-1



Figure 2-2

- ❹ Slide the media converter module fully into the bottom of selected slot to make sure that this module is firmly connected with the connector inside of the converter slot. (See Fig. 2-3.)
- ❺ Repeat Step 3~Step 4 for the installation of the other media converter module if needed.
- ❻ Fasten the fastening knobs clockwise to fix the media converter module(s). (See Fig. 2-4.)

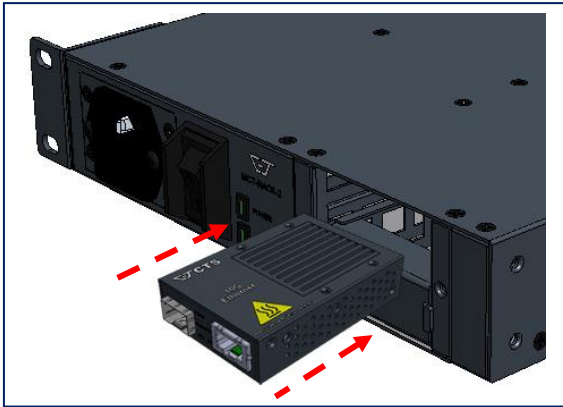

Figure 2-3

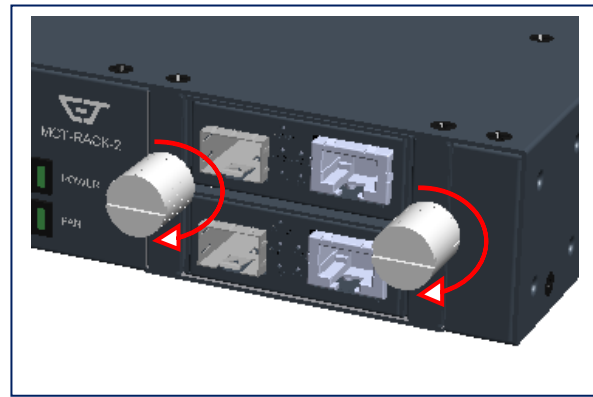

Figure 2-4

- 7 To pull out the module, you may connect the supplied pulling cable with the RJ-45 connector of the slide-in media converter module to pull it out more easily if needed. (See Fig. 2-5.)

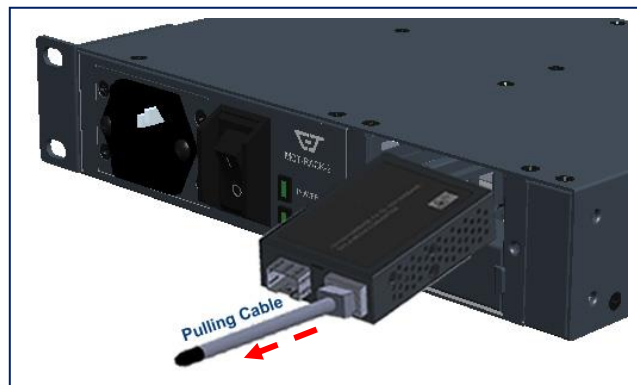

Figure 2-5

2.4 Installing MCT-RACK-2 Chassis

You can install MCT-RACK-2 chassis on a flat surface or mount it in a network equipment rack.



CAUTION

To prevent any damage or failure of MCT-RACK-2 and MCT series media converters, please **DO NOT** block the ventilation FAN hole.

Use the following guidelines when choosing a place to install the chassis:

- Firm and steady flat surface.
- Proper power outlet location, not too far from the device.
- Visually inspect the power cord and see that it is secured to the AC power connector.
- Make sure that there is proper heat dissipation from and adequate ventilation around the chassis. Do not place heavy objects on the chassis.

2.4.1 Desktop Installation

The chassis can be placed in any flat and steady surface with proper air ventilation. Four rubber feet with adhesive backing are provided for this kind of installation.

Procedures

- ① Attach rubber feet on the bottom at each corner of the device.
- ② Select a flat and steady surface to place the chassis.
- ③ Allow adequate space for ventilation between the device and the objects around it.

2.4.2 Rack Installation

Either you can install an 8.5-inch chassis in a 10-inch or standard EIA 19-inch network equipment rack. In the following sections, we will take MCT-RACK-2 chassis for example to separately demonstrate how to mount it in these sizes of rack space.



WARNING!

Please mount the Chassis firmly in rack, otherwise it may fall and cause the system damage and possible injury to personnel.

2.4.2.1 Install a Single MCT-RACK-2 Chassis in a 10-inch Rack

To install one set of MCT-RACK-2 in a single 10-inch rack space, you need the 19-inch rack-mount kit supplied with the chassis. Also follow the procedures listed below for step-by-step instructions to install your chassis in this rack space:

Step 1. Attach the supplied rack mounting brackets to the chassis:

- 1.1. Attach the supplied regular mounting bracket to one side of the chassis that you would like to install in the rack. (See Figure 2-6)
- 1.2. Attach the supplied regular mounting bracket to the other side of the chassis. (See Figure 2-6)

Step 2. Insert the screws provided in the rack-mount kit through each bracket and into the bracket mounting holes in the chassis. (See Figure 2-6)

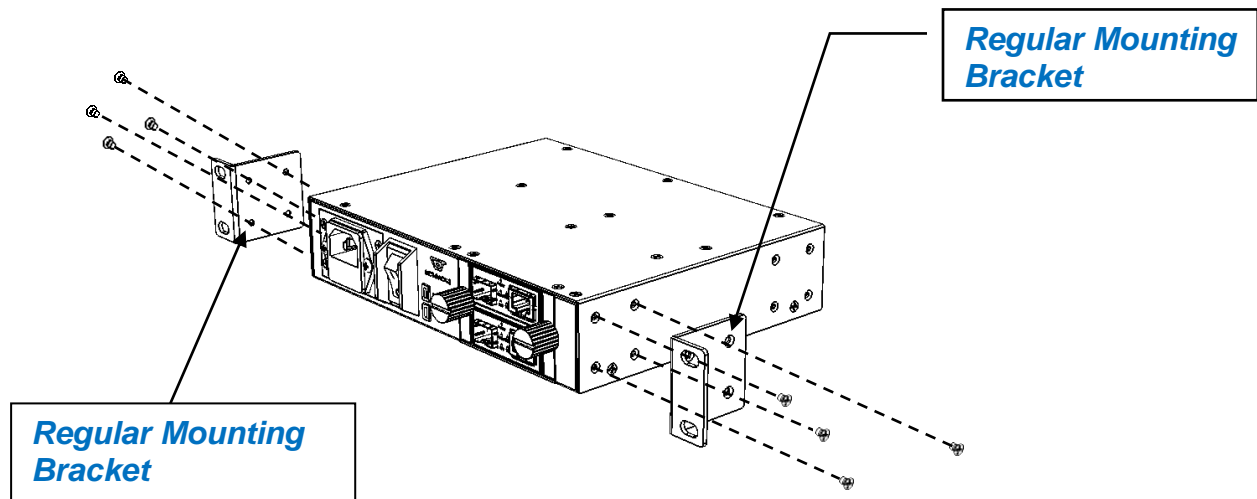

Figure 2-6. Chassis Mounting in 10-inch Rack

Step 3. Then, tighten the screws with the screwdriver to secure each bracket.

Step 4. Align the mounting holes in the brackets with the desired holes in the rack, and insert screws through each bracket and into the rack.

Step 5. Then, tighten the screws with the screwdriver to secure mounting brackets to the rack.

Step 6. Please ensure that the FAN ventilation hole is not blocked.

2.4.2.2 Install a Single MCT-RACK-2 Chassis in a 19-inch Rack

Alternatively, to install one set of MCT-RACK-2 in a single 19-inch rack space, you need the 19-inch rack-mount kit supplied with the chassis as well. Also follow the procedures listed below for step-by-step instructions to install your chassis in this rack space:

Step 1. Attach the supplied rack mounting brackets to the chassis:

- 1.1. Attach the supplied regular mounting bracket to one side of the chassis that you would like to install in the rack. (See Figure 2-7)
- 1.2. Attach the supplied long mounting bracket to the other side of the chassis. (See Figure 2-7)

Step 2. Insert the screws provided in the rack-mount kit through each bracket and into the bracket mounting holes in the chassis. (See Figure 2-7)

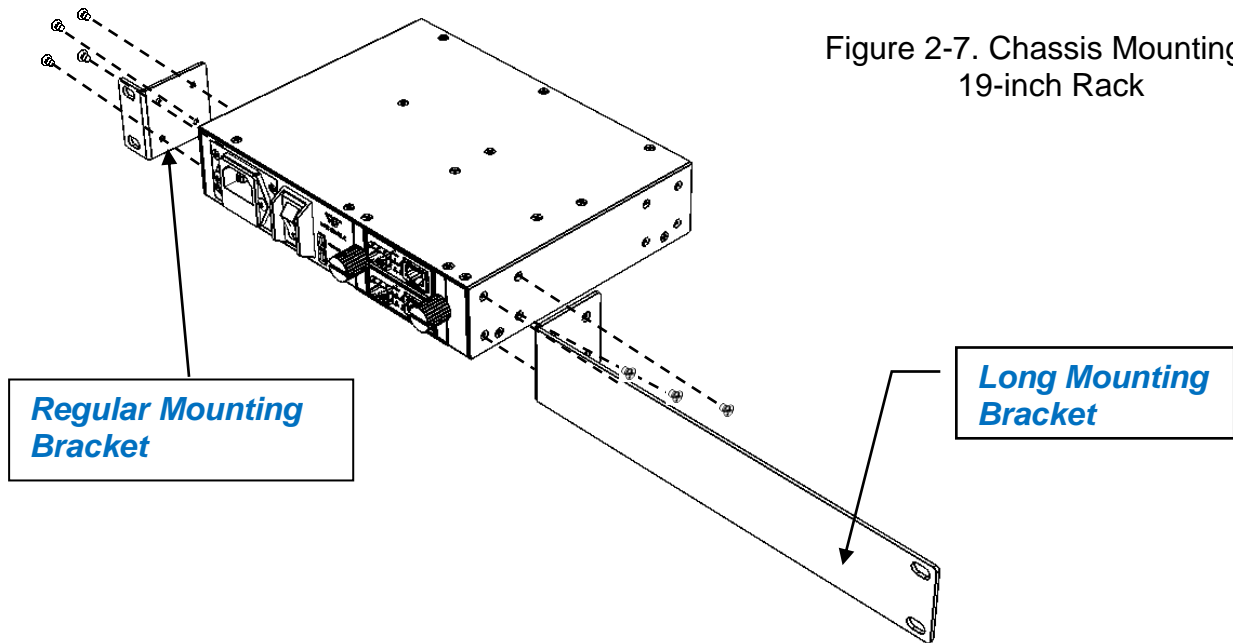

Figure 2-7. Chassis Mounting in 19-inch Rack

Step 3. Then, tighten the screws with the screwdriver to secure each bracket.

Step 4. Align the mounting holes in the brackets with the desired holes in the rack, and insert screws through each bracket and into the rack.

Step 5. Then, tighten the screws with the screwdriver to secure mounting brackets to the rack.

Step 6. Please ensure that the FAN ventilation hole is not blocked.

2.5 Powering on MCT-RACK-2 Chassis

MCT-RACK-2 can be used with AC power supply 100-240 V, 50/60 Hz, 0.75A~0.5A. After MCT-RACK-2 is turned on, the Power LED indicators should light in green color. For more details about the power LED description, please refer to Section [1.4 LED Definitions](#).

Power Failure

In the event of power failure, just turn off and turn on the power switch.

Maintenance

This chassis is easy to maintain. The procedures are suggested when you would like to identify faults and perform hardware replacement.

3.1 Fault Identification

Identifying faults can greatly reduce the times required to find problem and solution. Users may perform local check to find the problems.

3.1.1 Local Check

Users can perform local check by observing LED indicators status and the network connections.

- When the whole system fails to function,
 1. Check Power LED status
 2. Check Power connection
 3. Reset power

- When certain network link fails to function,
 1. Locate the abnormal port of the slide-in converter module
 2. Check MCT series media converter connection with the connector inside of the converter slot
 3. Check Power LED of the slide-in converter module
 4. Check LINK/ACT/Speed LED of the slide-in converter module
 5. Check Status LED of the slide-in converter module
 6. Check UTP and fiber cable connections between the slide-in converter module and the connected devices
 7. Unplug and re-plug this slide-in converter module into the converter slot to reset it.

3.2 Hardware Replacement Procedures



WARNING!

The chassis contains no user-serviceable parts. **DO NOT, UNDER ANY CIRCUMSTANCES, open and attempt to repair it.**

Failure to observe this warning could result in personal injury or death from electrical shock.

Failure to observe the above warning will immediately void any Warranty.

3.2.1 Replace MCT Series Media Converter

- When the converter module fails to function,
 1. Remove the existing MCT series media converter by loosening the fastening knobs.
 2. Insert a new MCT series media converter carefully into the converter slot.
 - ✓ Make sure that this MCT series media converter is firmly connected with the connector inside of the converter slot.
 3. Fasten the fastening knobs.



CONNECTION TECHNOLOGY SYSTEMS

18F-6, No.79, Sec.1, Xintai 5th Rd.,
XiZhi Dist., New Taipei City 221, Taiwan(R.O.C)

Tel: +886-2-2698-9661

Fax: +886-2-2698-9662

Dir.Line:+886-2-2698-9201

www.ctsystem.com