



IPS-3106-SE-PB

Managed Industrial PoE Ethernet Switch

User's Guide

Version: 1.2

Revision History

Version	Date	Changes
1.0	04/19/2018	First release
1.1	06/12/2018	Add new features and CTS branches' contact information.
1.2	09/26/2018	Add the new feature

FCC Warning

This equipment has been tested and found to comply with the limits for a Class A digital device, pursuant to Part 15 of the FCC Rules. These limits are designed to provide reasonable protection against harmful interference when the equipment is operated in a commercial environment. This equipment generates, uses, and can radiate radio frequency energy and, if not installed and used in accordance with this user's guide, may cause harmful interference to radio communications. Operation of this equipment in a residential area is likely to cause harmful interference in which case the user will be required to correct the interference at their own expense.

CE Mark Warning

This is a Class A product. In a domestic environment, this product may cause radio interference in which case the user may be required to take adequate measures.

Trademarks

CTS is a registered trademark of Connection Technology Systems Inc.
All trademarks belong to their respective proprietors.

Contents subject to change without prior notice.

Copyright Statement

Connection Technology Systems Inc Copyright © 1998-2018

This publication may not be reproduced as a whole or in part, in any way whatsoever unless prior consent has been obtained from Connection Technology Systems Inc.

CTS Contact Information

■ **Headquarter/Manufacturer:**

Connection Technology Systems Inc.

18F-6, No.79, Sec.1, Xintai 5th Rd.,
XiZhi Dist., New Taipei City 221, Taiwan(R.O.C)
Tel: +886-2-2698-9661
Fax: +886-2-2698-9662
Dir.Line:+886-2-2698-9201
www.ctsystem.com

■ **Global Authorized Representatives:**

Connection Technology USA Inc.

40538 La Purissima Way, Fremont, CA 94539, USA
Tel: +1-510-509-0304
Sales Direct Line: +1-510-509-0305
E-mail:cts_us@ctsystem.com

Connection Technology Systems Japan

Higobashi Bldg, No3 R201, 1-23-13, Edobori, Nisi-ku,
Osaka 550-0002, Japan
Tel: +81-6-6450-8890
E-mail: cts_japan@ctsystem.com

Connection Technology Systems NE AB

August Barks Gata 21,
421 32 Västra Frölunda, Sweden
Tel: +46-31-221980
E-mail: info@ctsystem.se

COMPONET Handels GmbH

Hirschstettner Straße 19-21/Stiege I
A-1220 Wien, Austria
Tel: +43-1-2350-5660
E-mail: office@componet.at

Table of Contents

Revision History	ii
CTS CONTACT INFORMATION	III
TABLE OF CONTENTS	IV
CHAPTER 1. INTRODUCTION	2
1.1 OVERVIEW OF IPS-3106-SE-PB	2
1.2 KEY FEATURES	3
1.3 FRONT & REAR & TOP PANELS	5
1.3.1 Front and Rear Panels	5
1.3.2 Top Panel	6
1.4 LED DEFINITIONS	7
1.5 CABLE SPECIFICATIONS	9
CHAPTER 2. INSTALLATION	10
2.1 INSTALLATION REQUIREMENTS	11
2.2 CHECKING THE PACKAGE CONTENTS	11
2.3 INSTALLING THE MANAGED INDUSTRIAL PoE GIGABIT ETHERNET SWITCH	12
2.3.1 DIN-Rail Installation	12
2.3.2 Grounding the Managed Industrial PoE Gigabit Ethernet Switch	13
2.4 POWERING THE MANAGED INDUSTRIAL PoE GIGABIT ETHERNET SWITCH	14
2.5 CONNECTING THE SWITCH TO NETWORK	16
2.6 INSTALLING AND REMOVING SFP MODULES	16
2.6.1 Installing SFP Modules	16
2.6.2 Removing SFP Modules	16
2.7 CONNECTING THE SWITCH TO CONSOLE PORT	17
CHAPTER 3. OPERATION	18
3.1 NETWORK MANAGEMENT	18
CHAPTER 4. MAINTENANCE	20
4.1 FAULT IDENTIFICATION	20
4.1.1 Local Check	20
4.1.2 Remote Check	21
4.2 HARDWARE REPLACEMENT PROCEDURES	21
4.3 FIRMWARE UPGRADE	21

About this manual

In this user's guide, it will not only clearly introduce CTS IPS-3106-SE-PB Managed Industrial PoE Gigabit Ethernet Switch but tell you how to install this Switch with detailed instructions.

Organization of the Manual

- Chapter 1 "Introduction" describes the features of the Managed Industrial PoE Gigabit Ethernet Switch
- Chapter 2 "Installing the Managed Industrial PoE Gigabit Ethernet Switch"
- Chapter 3 "Operation"
- Chapter 4 "Maintenance"

1

Introduction

CTS's Managed Industrial Switch is designed to meet the emerging FTTX & Metro Ethernet requirements at the industrial environment. When massive fiber ports need to be deployed, this managed switch series provide the best performance and price ratio.

1.1 Overview of IPS-3106-SE-PB

IPS-3106-SE-PB, a Managed Industrial PoE Gigabit Ethernet Switch, has 4 x 10/100/1000Base-T up to 30W PoE ports and 2 x 100/1000Base-X SFP ports in the front panel. It is designed to meet the massive needs for Gigabit Ethernet network deployments and aim at industrial PoE applications that demand a wide range of operating temperature (-40°C ~ 75°C). This Managed Industrial PoE Switch also provides high performance, store and forward switching capability plus other advanced features such as QoS, VLAN, Spanning Tree, LACP and so on.

LED indicators located on the front panel ease the users' effort to monitor and manage the network status. The built-in management module allows users to configure, control and monitor the system locally via console or remotely via SNMP_ based management system.

In the harsh environment, this Managed Industrial PoE Gigabit Ethernet Switch is a reliable solution to the delivery of power over Ethernet for any network devices. With the power redundancy, users can prevent the network disconnection from the unexpected power outage. Besides, it can be used as a stand-alone switch. You can easily mount it with the provided DIN-rail at industrial sites as well.

1.2 Key Features

■ Interface

- 4 x 10/100/1000Mbps RJ-45, Max.30W PoE/PSE
- 2 x 100/1000Mbps SFP Slot
- Console: 1 x RS-232 (RJ-45)

■ Standards

- Support IEEE802.3 10Base-T
- Support IEEE802.3u 100Base-TX/FX
- Support IEEE802.3ab 1000Base-T
- Support IEEE802.3az EEE
- Support IEEE802.3z 1000Base-X
- Support IEEE802.1p Priority
- Support IEEE802.1q Tag VLAN
- Support IEEE802.3x Flow Control
- Support IEEE802.1D/IEEE802.1w STP/RSTP
- Support IEEE802.3af Power over Ethernet
- Support IEEE802.3at Power over Ethernet Enhancements
- Support IEEE802.1x Authentication Network Access Control

■ H/W Specification

- Store and Forward Switching Mechanism
- Auto Crossover for MDI/MDI-X in TP Port
- Auto Negotiation in TP Port
- Support Auto-Sensing for fiber ports
- Half/Full Duplex Mode Operation
- Jumbo Frame up to : 10K Bytes
- MAC Address Table : 8K
- Non-Blocking Switching Fabric : 12Gbps
- VLANs support up to 2K VLAN Groups
- 1x Digital Output for fault alarm notification (Power, Ports, Digital Input)
- 1x Digital Input (Dry Contact)
- 6KV Surge Immunity on RJ-45 Copper Port (K.21*)
- Dual Power Input (24~54 VDC)

■ Switching Features

- Support IEEE802.1q Tag Based VLAN
- Support IGMP v1/v2/v3 snooping
- IGMP fast leave
- IGMP filtering via filtering profile
- Support QoS Based on P-bit
- QoS classification based on IEEE802.1p, TOS/DSCP
- 802.1Q Tunneling (QinQ)
- Support Strict Priority Queuing(SPQ)
- Support Weighted Round Robin(WRR)

- Support Port Trunking
- CPU temperature alarm notification
- L2PT (Layer 2 Protocol Tunneling)
- VLAN Translation
- Proprietary Fast Ring v2 (<50ms) and Chain (<1 second) redundancy protocols for fast redundancy after encountering connection issues

■ Network Management

- Console
- Telnet/CLI
- Web
- RADIUS authentication
- SNMP v1/v2c/v3
- DHCP Client
- FTP/HTTP/TFTP Firmware Upgrade
- Dual Image
- SNTP
- SSHv2
- Eventlog
- Syslog

■ Operation Environment

- Operating Temperature: -40°C~75°C

1.3 Front & Rear & Top Panels

1.3.1 Front and Rear Panels

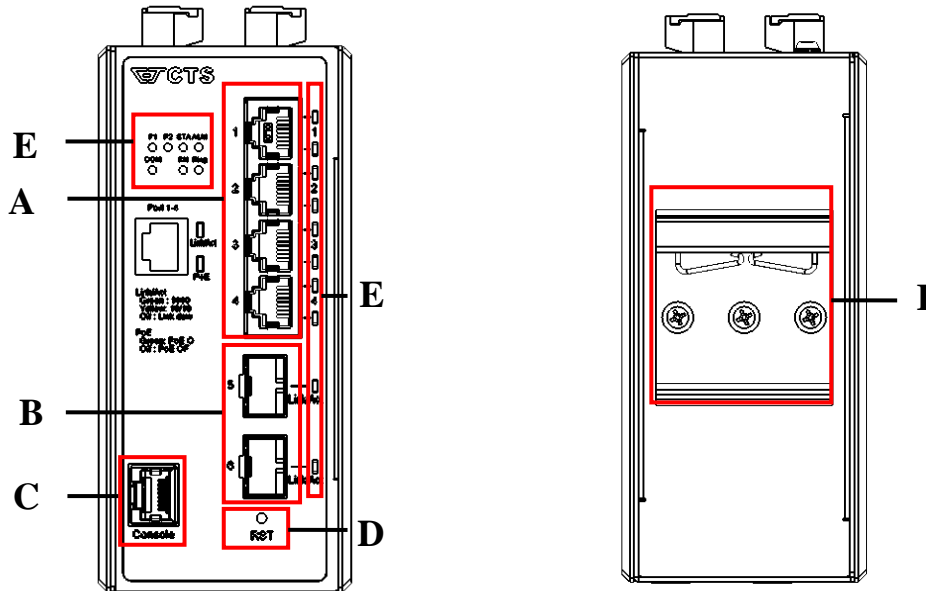

Figure 1-1. Front and Rear Panels of IPS-3106-SE-PB

The interfaces on the front and rear panels of the Managed Industrial PoE Gigabit Ethernet Switch are described below:

A. 4 x 10/100/1000Base-T RJ-45 Ports (Ports 1-4)

B. 2 x 100/1000Base-X SFP Ports (Ports 5-6) : Uplink Ports.

C. Console Port (RJ-45 to RS-232) :

- An asynchronous serial console port supports the RS-232 electrical specification. The console port can be used to manage the device, and the serial console port settings should be configured as 9600, 8, n, 1.

D. Reset Button :

- Press the reset button for 5~10 seconds, then release it to restart the system.
- Press the reset button for more than 10 seconds, then release it to reset the Managed Switch. The settings will be back to the factory defaults and restart the system.

E. LEDs :

- Includes Power LEDs of P1 and P2, STA Status LED, ALM LED, COM LED, RM LED, Ring LED, Link/Act LEDs of 1~6 ports and PoE LEDs of 1~4 ports. For more details on LEDs description, please refer to [Section 1.4 LED Definitions](#).

F. Din-Rail Metal Spring (For more information, please refer to [Section 2.3.1](#))

1.3.2 Top Panel

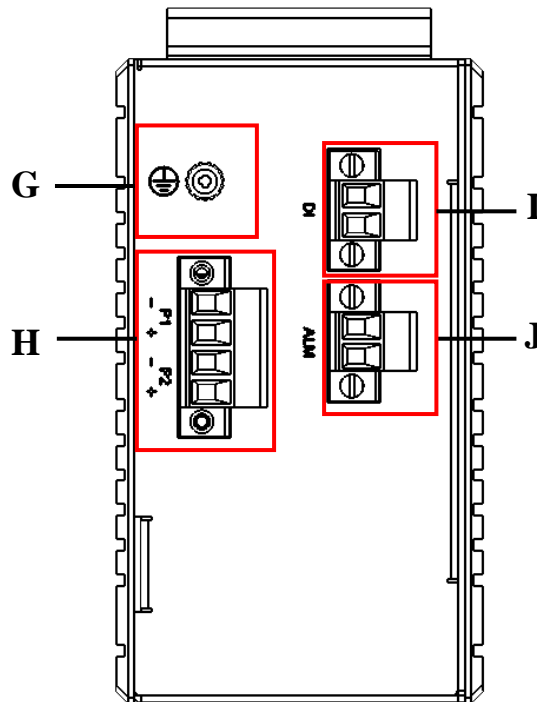

Figure 1-2. Top Panel of IPS-3106-SE-PB

The interfaces on the top panel of the Managed Industrial PoE Gigabit Ethernet Switch are described below:

- G. Ground Screw** (For more information, please refer to [Section 2.3.2](#))
- H. Terminal Block for Power Supply** (For more information, please refer to [Section 2.4](#))
- I. Digital Input** (For more information, please refer to [Section 2.4](#))
- J. Digital Output for Relay Alarm** (For more information, please refer to [Section 2.4](#))

1.4 LED Definitions

The Managed Industrial PoE Gigabit Ethernet Switch is Plug & Play compliant. The real-time operational status can be monitored through a set of LED indicators located on the front panel.

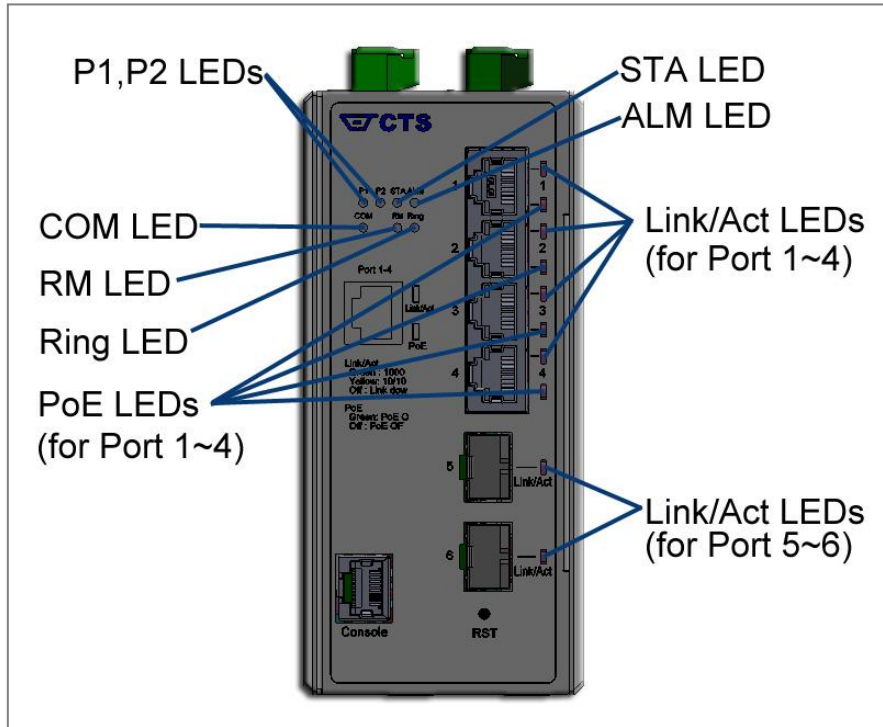

Figure 1-3. LEDs of IPS-3106-SE-PB

LED	Color	Operation
P1 (Power)	OFF	Device is powered down or works abnormally.
	Green	Lit when this power is in normal operation.
P2 (Power)	OFF	Device is powered down or works abnormally.
	Green	Lit when this power is in normal operation.
STA (System Status)	Green	Lit when the system is working normally.
	Orange	Blinking when press the Reset button for more than 10 seconds and then release to reset (return to factory default settings) and restart the system. The LED indicator will blink in orange color for three times.
		Lit when the device is booting up or press the Reset button for 5~10 seconds and then release to restart the system.
ALM (Alarm)	OFF	One or redundant power supply is up since the system is booted up.
	Red	One of redundant power supply is down since the system is booted up.

Ring (Function)	OFF	Ring Detection is disabled.
	Green	Lit when Ring Detection works normally and no ring port is link down. Blinking when the ring port of another device is link down that results in abnormal Ring Detection.
	Orange	Blinking when the ring port of this Switch is link down that results in abnormal Ring Detection.
RM (Ring Master)	OFF	Off when the role of this Switch is Slave in case Ring Detection is enabled.
	Green	Lit when the role of this Switch is Master in case Ring Detection is enabled.
COM	OFF	Either the console port is not activated or no session exists.
	Green	Lit when the console port is activated and the session exists.
Link/ACT (1~4 Ports)	OFF	No connection exists.
	Orange	Lit when 10/100Mbps TP port link is up. Blinking when TP port is receiving and transmitting data at the speed of 10/100Mbps.
	Green	Lit when 1000Mbps TP port link is up. Blinking when TP port is receiving and transmitting data at the speed of 1000Mbps.
Link/ACT (5~6 Ports)	OFF	No connection exists.
	Orange	Lit when 100Mbps Fiber port link is up. Blinking when Fiber port is receiving and transmitting data at the speed of 100Mbps.
	Green	Lit when 1000Mbps Fiber port link is up. Blinking when Fiber port is receiving and transmitting data at the speed of 1000Mbps.
PoE (1~4 Ports)	OFF	PoE is disabled or no power is supplied with the PD when PoE is enabled.
	Green	Lit when PoE is enabled and starts supplying the power. (Note: Once PoE LED indicator that belongs to the specific PoE port without connecting any PD lights in green color, it stands that this PoE port is under the “Injector-30Watt” mode. It strongly recommends that please do not connect any network device (e.g. NIC) not supporting PoE function to this PoE port, since it may cause great damage to your network device. For more details on PoE operation mode settings, please refer to IPS-3106-SE-PB Network Management User’s Manual.)

1.5 Cable Specifications

The following table contains various cable specifications for the Managed Industrial PoE Gigabit Ethernet Switch. Please make sure that you use the proper cable when connecting the Switch.

Cable Type	Description
10Base-T	UTP Category 3, 4, 5 (100 meters max.) EIA/TIA- 568 150-ohm STP (100 meters max.)
100Base-TX	UTP Cat. 5 (100 meters max.) EIA/TIA-568 150-ohm STP (100 meters max.)
1000Base-T	UTP Cat. 5e (100 meters max.) UTP Cat. 5 (100 meters max.) EIA/TIA-568B 150-ohm STP (100 meters max.)
100BASE-FX	Multi-mode fiber module(2km) / Single-mode fiber module
1000BASE-SX	Multi-mode fiber module (550m)
1000BASE-LX	Single-mode fiber module (10km)
1000BASE-LH	Single-mode fiber module (30km/50km)
1000BASE-ZX	Single-mode fiber module (80km)
SFP Transceiver	SFP Transceiver for 1000BASE-SX Multi-mode fiber module (550m) SFP Transceiver for 1000BASE-LX Single-mode fiber module (10km) SFP Transceiver for 1000BASE-LH Single-mode fiber module (30km/50km) SFP Transceiver for 1000BASE-ZX Single-mode fiber module (80km)

2

Installation

To properly install IPS-3106-SE-PB Managed Industrial PoE Gigabit Ethernet Switch, please follow the procedures listed below. These procedures will be respectively described in detail in the following sections.

- Installation Requirements
- Checking the Package Contents
- Installing the Managed Industrial PoE Gigabit Ethernet Switch
- Powering on the Managed Industrial PoE Gigabit Ethernet Switch
- Connecting the Managed Industrial PoE Gigabit Ethernet Switch to the Network

2.1 Installation Requirements



ATTENTION

Be sure to power off before installing or wiring your Managed Industrial PoE Gigabit Ethernet Switch.

Be sure to calculate the maximum possible current in each power wire and common wire. If the current goes above the maximum ratings, the wiring could overheat, causing serious damage to your equipment.

Be sure to read and follow important guidelines as below:

- Do not run signal or communications wiring and power wiring through the same wire conduit. Wires with different signal characteristics should be routed separately to avoid interference.
- It is recommended that wiring which shares similar electrical characteristics can be bundled together.
- Keep input wiring and output wiring separate and label the wiring to all devices in the system if necessary.

2.2 Checking the Package Contents

Unpack the package carefully and check the package contents. The standard package should contain the following items:

- One set of Managed Industrial PoE Gigabit Ethernet Switch
- Documentation CD x 1

Note: If any of the above items is found missing or damaged, please contact your local sales representative for support or replacement.

2.3 Installing the Managed Industrial PoE Gigabit Ethernet Switch



ATTENTION

This product is intended to be mounted to a well-grounded mounting surface, such as a metal panel.

2.3.1 DIN-Rail Installation

Just follow the steps below to complete the DIN-Rail installation for your IPS-3106-SE-PB if needed.

STEP 1 : Insert the top of the DIN-Rail into the slot just below the metal spring

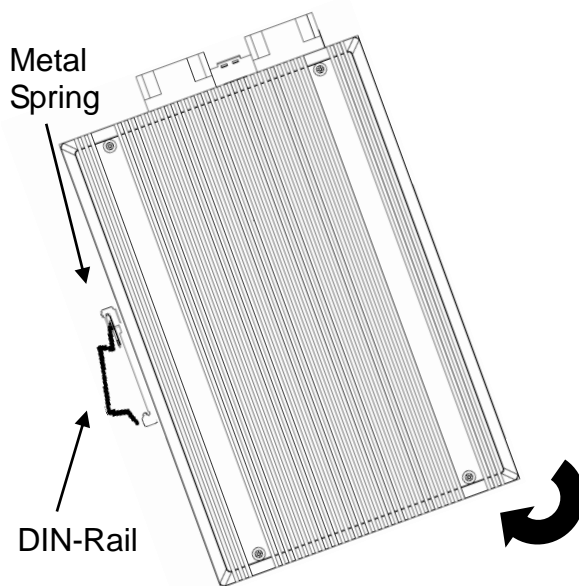

STEP 2 : The DIN-Rail attachment unit will be snapped into place as shown

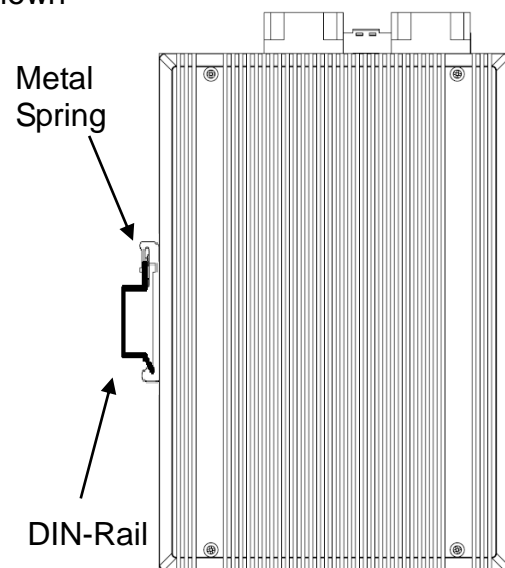

2.3.2 Grounding the Managed Industrial PoE Gigabit Ethernet Switch

Grounding helps to limit the effects of noise due to electromagnetic interference (EMI). Be sure to install the ground connection from the ground screw to the grounding surface before connecting devices.

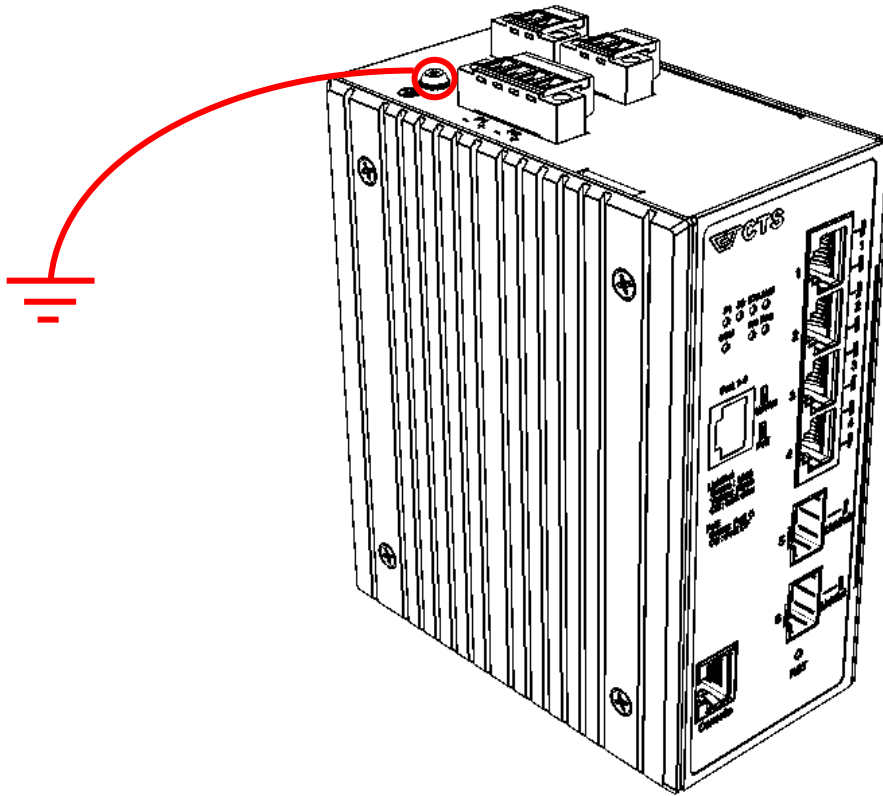

Figure 2-1 Grounding Wiring for IPS-3106-SE-PB

2.4 Powering the Managed Industrial PoE Gigabit Ethernet Switch

The Managed Industrial PoE Gigabit Ethernet Switch can be used with DC power 24~54 VDC through the terminal block. The terminal block is located on the upper panel of this Switch. Before powering on the Managed Industrial PoE Gigabit Ethernet Switch, please make sure that network cables and power cables are securely connected.



ATTENTION

Before connecting the Managed Industrial PoE Gigabit Ethernet Switch to the DC power inputs, make sure the DC power source voltage is stable.

Wiring of the Terminal Block for Power Supply/Digital Output for Relay Alarm/Digital Input

- P1 and P2 (Power Inputs):** Two sets of power inputs are located on the terminal block. For power redundancy purpose, both the P1 and P2 need to be configured. The redundant power input will take over seamlessly when one power source is down to protect your device or network from the loss of power.

Power Input Configuration:

Loosen the wire-clamping screws by using a flat-head screwdriver to insert the positive and negative wires of 14 AWG at least we suggest into the “+” and “-” contacts on the terminal block respectively. P1 and P2 allow the power input that ranges from 24~54 VDC. Tighten the wire-clamping screws to fix wires of 14 AWG by using a flat-head screwdriver.

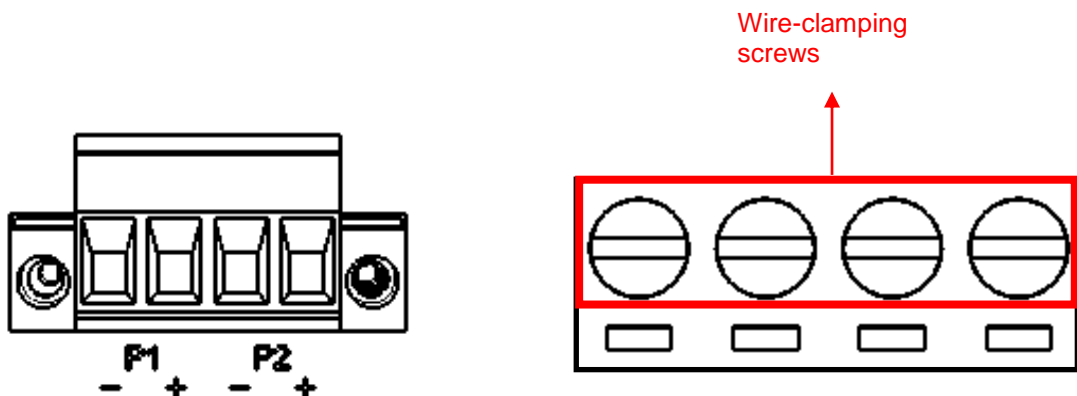

■ Digital Output for Relay Alarm Configuration:

A pair of contacts located on the Digital Output are used to connect alarm devices such as speakers or LEDs to alert users when the digital input alarm, the redundant power failure or any port-link failure occurs. For more details on these settings, please refer to IPS-3106-SE-PB Network Management User's Manual. The default contact is normal open, the capacity of relay alarm is 1A/30VDC.

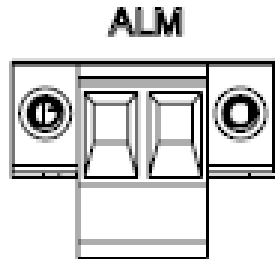

Loosen/tighten the wire-clamping screws to insert/fix alarm-device wires by using a flat-head screwdriver as described above.

■ Digital Input (Dry Contact): A voltage-free connector that is used to decide whether the trigger occurs or not by detecting its open/close status. The configuration is as follows:

- Open: Logic Level 0
- Close: Logic Level 1

Digital Input Configuration:

A pair of contacts located on the Digital Input. Loosen the wire-clamping screws by using a flat-head screwdriver to insert the wires into the contacts on the Digital Input.

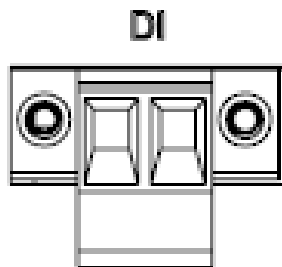

Tighten the wire-clamping screws to fix the wires by using a flat-head screwdriver as described above.

Note: *If there is no power redundancy, the relay alarm is not available.*

2.5 Connecting the Switch to Network

Connect to Network

This Managed Industrial PoE Gigabit Ethernet Switch has 2 uplink ports (SFP) and 4 downlink 10/100/1000Mbps RJ-45 ports for you to implement it in your Industrial PoE environment. These 2 SFP ports can be plugged with 100Base-FX or 1000Base-X SFP Fiber transceiver. All RJ-45 ports can be plugged with 10/100/1000Base-T UTP cable. The connection of the fiber port must be matched, i.e. Transmitter to Receiver, and vice versa.

2.6 Installing and Removing SFP Modules

2.6.1 Installing SFP Modules

To connect the fiber transceiver and LC cable, use the following guidelines:

1. Position the SFP transceiver with the handle on top.
2. Locate the triangular marking in the slot and align it with the bottom of the transceiver.
3. Insert the SFP transceiver into the slot until it clicks into place.
4. Make sure the module is seated correctly before sliding the module into the slot. A click sounds when it is locked in place.

Note: If you are attaching fiber optic cables to the transceiver, continue with the following step. Otherwise, repeat the previous steps to install the remaining SFP transceivers in the device.

1. Remove the protective plug from the SFP transceiver.

Note: Do not remove the dust plug from the transceiver if you are not installing the fiber optic cable at this time. The dust plug protects hardware from dust contamination.

2. Insert the fiber cable into the transceiver. The connector snaps into place and locks.
3. Repeat the previous procedures to install any additional SFP transceivers in the switch. The fiber port is now set up.

2.6.2 Removing SFP Modules

To disconnect an LC connector, use the following guidelines:

1. Press down and hold the locking clips on the upper side of the optic cable.
2. Pull the optic cable out to release it from the transceiver.
3. Hold the handle on the transceiver and pull the transceiver out of the slot.

2.7 Connecting the Switch to Console Port

The industrial switch supports a secondary means of management. By connecting the RJ45 to RS232 serial cable between a COM port on your PC (9-pin D-sub female) and the switch's RJ45 (RJ45) port, a wired connection for management can be established.



3

Operation

A built-in management module of the Managed Industrial PoE Gigabit Ethernet Switch provides users flexible interfaces to configure, control and monitor the system remotely and locally. To know the further information about the operation of this switch, please refer to IPS-3106-SE-PB Network Management User's Manual for the detailed management functions and required installation and operation procedures.

3.1 Network Management

The following is a list of management options available in this Managed Industrial PoE Gigabit Ethernet Switch:

- Local Console Management
- Telnet Management
- SNMP Management
- Web Management

Local Console Management

Users may connect a Terminal or PC running the Terminal Emulation program (such as Putty or Tera Term) with the following serial console port settings, to the Managed Switch console port directly via RS-232 cable to configure , control and monitor the system. This is often referred to as Out-Of-Band management.

Baud rate:	9600
Data bits:	8
Parity:	none
Stop bits:	1
Flow control:	none

Console management is useful when there is no network connection to the Switch, for instance configuring the Managed Switch for the first time.

Telnet Management

Telnet is done through the network. Once there is a network connection to the Managed Switch, users can use Telnet to configure, control and monitor the system. Using the network connection to

manage is often referred to as In-Band-Management.

SNMP Management

SNMP is also In-Band-Management and requires a network connection to the Managed Switch. The Managed Switch private Management Information Bases (MIB) is provided for SNMP-based network management program to configure, control and monitor the system.

Web Management

Web Management is done over the network. Once the Managed Switch is available on the network, you can login and monitor the status of it through a web browser remotely or locally. Local console-type Web management, especially for the first time use of the Managed Switch to set up the needed IP, can also be done through one of the 10/100/1000Base-T 8-pin RJ-45 ports located on the front panel of the Managed Switch. Direct RJ-45 LAN cable connection between a PC and the Managed Switch is required for this management.

4

Maintenance

This Managed Industrial PoE Gigabit Ethernet Switch is easy to maintain. The procedures are suggested when you would like to identify faults, perform hardware replacement and do the firmware upgrade.

4.1 Fault Identification

Identifying faults can greatly reduce the time required to find problem and solution. Users may perform local check or remote check to find the problems.

4.1.1 Local Check

Users can perform local check by observing LED indicators status or check system setup and configuration through console connection.

- When the whole system fails to function,
 1. Check Power LED status
 2. Check Power connection
 3. Reset power

- When certain network link fails to function,
 1. Locate the port of the switch
 2. Check LINK/ACT LED of the port
 3. Check Status LED of the port
 4. Check cable connection between the port and the connected device
 5. Reset power

- When local Console fails to function,
 1. Check COM LED status
 2. Check Console port connection
 3. Check Console configuration
 4. Reset power

4.1.2 Remote Check

Users may check the Managed Industrial PoE Gigabit Ethernet Switch through SNMP manager remotely. For detailed procedures, please refer to the Network Management User's Manual.

4.2 Hardware Replacement Procedures



WARNING!

The Managed Switch contains no user-serviceable parts. DO NOT, UNDER ANY CIRCUMSTANCES, open and attempt to repair it.

Failure to observe this warning could result in personal injury or death from electrical shock.

Failure to observe the above warning will immediately void any Warranty.

4.3 Firmware Upgrade

This Managed Industrial PoE Gigabit Ethernet Switch may perform the firmware upgrade when required. The latest firmware can be obtained from your sales representative. For the detailed upgrade procedures, please refer to IPS-3106-SE-PB Network Management User's Manual.



CONNECTION TECHNOLOGY SYSTEMS

18F-6, No.79, Sec.1, Xintai 5th Rd.,

XiZhi Dist., New Taipei City 221, Taiwan(R.O.C)

Tel: +886-2-2698-9661

Fax: +886-2-2698-9662

Dir.Line:+886-2-2698-9201

www.ctsystem.com